

# Deburring

Deburring  
TOOLS

## contents

<u>2</u>	<u>One Pass Deburring</u>
<u>4</u>	<u>Burraway®</u>
<u>12</u>	<u>Burr-Off®</u>
<u>16</u>	<u>Micro-Limit</u>
<u>20</u>	<u>Ellipti-Bur®</u>
<u>24</u>	<u>Nobur® Tool</u>

# One pass deburring

*Deburring holes is usually a costly and time-consuming operation. The back sides of holes are particularly difficult, as they are frequently inaccessible with conventional deburring tools.*

*Cogsdill Tool Products offers you a better way to get rid of those troublesome burrs. BURRAWAY® and BURR-OFF® mechanical hole-deburring tools remove burrs on the front, back, or both sides of drilled holes in **one pass**. . . fast, easy, and economical solutions for your hole-deburring problems!*

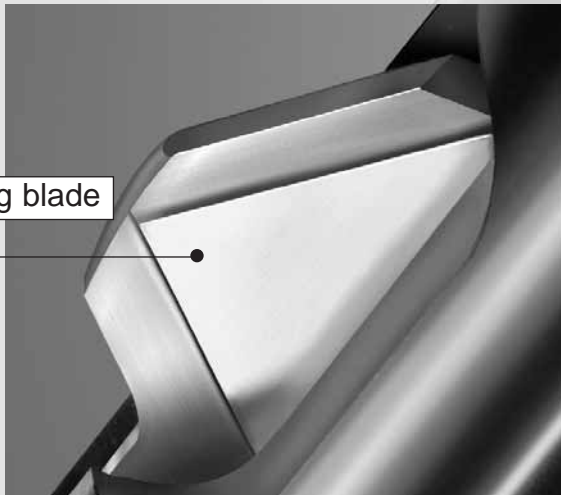

**Deburr both sides**  
of holes in  
one **fast** pass

# overview

The BURRAWAY® features a replaceable and inexpensive cutting blade which can be adjusted to control the amount of edge break for consistent results from part to part. The tool can remove feather edges or heavier burrs, on both sides of the hole, working from one side only. The BURRAWAY can be used in fixed spindles or in portable power tools – no need for complicated fixturing, and no special operator skills are required.

The BURR-OFF® is suited to high-production, automated deburring operations; the open-slot design allows chips to clear easily. The original “clothespin” tool, with its integral cutting edges, deburrs thousands of holes and may be reground for even longer life.

Other, more specialized hole-deburring and countersinking tools are also available from Cogsdill:

The MICRO-LIMIT drive with piloted countersink is designed for precision depth-controlled countersinking of holes. Depth of cut can be pre-set for accurate and consistent results.

The ELLIPTI-BUR® deburrs irregular hole surfaces which are generated by drilling into curved surfaces, or by drilling at an angle.

The NOBUR® Tool is a manually actuated deburring tool for low production requirements. The tool is used on multi-walled parts or intersecting holes, and for removing severe burrs or producing non-qualified chamfers.

# Deburring TOOLS





*We are pleased to offer the  
broadest array of hole-deburring tools  
in the marketplace. Let us help you meet  
your production needs with fast, easy,  
and inexpensive solutions  
to tough deburring problems.*

---

**COGSDILL TOOL PRODUCTS, INC.**

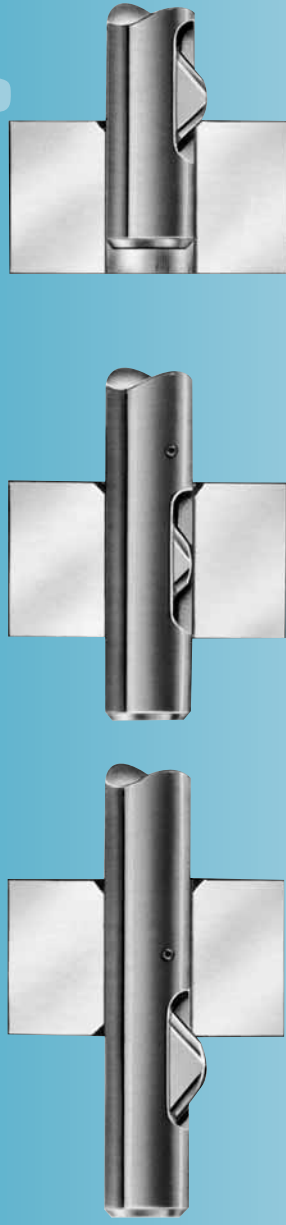
## How it works



- 1.** Upon entry, spring tension holds the *replaceable* and *adjustable* cutting blade in the extended position as it removes the burr on the front of the hole.
- 2.** As the feed load increases, the pre-set spring tension is exceeded and the blade retracts automatically as the tool passes through the workpiece. (The crowned and polished top surface of the blade will *not* mar the inside surface of the hole.)
- 3.** Spring tension again causes the blade to extend as it emerges from the ID of the part; the burr is removed on the back side of the hole on the return stroke.

**A one-pass solution**  
to your  
hole-deburring  
problems!

*BURRAWAY® tools are available in both inch and metric programs (see tool specifications, pages 6–9). Tools for the inch program feature imperial (inch) hardware (adjusting screw); tools for the metric program have metric screws. Both are available from stock at standard prices.*



**Burraway tools feature an inexpensive, replaceable cutting blade which adjusts to control the amount of edge break.**

## Design features

All BURRAWAY® tools operate on the same basic principle, but vary slightly in design as determined by tool size:

**Type A** tools (inch program; for hole sizes from .093 through .203 in.) and **Type MA** tools (metric program; sizes from 2 to 5mm) are a two-piece construction (arbor assembly and adapter). All Type A and MA arbor assemblies are interchangeable with their respective shank adapters.

**Type B** tools (inch program; for hole sizes from .218 through .750 in.) and **Type MB** tools (metric program; sizes from 5.5 through 19mm) are a single-piece construction.

**Type C** tools (inch program; for hole sizes from .750 through 2 in.) and **Type MC** tools (metric program; sizes from 20 through 50mm) are also a single-piece construction.

A tension adjustment mechanism controls the amount of edge break for consistent results from piece to piece. Types A, MA, B, and MB tools have a tension adjustment screw located in the shank end; Types C and MC tools control depth of cut with a tension adjustment rod.

## Blade options

BURRAWAY tools are furnished with double-acting blades for burr removal on both the front and back sides of the hole. Blades for front-cutting or back-cutting only are available from stock at no additional charge.

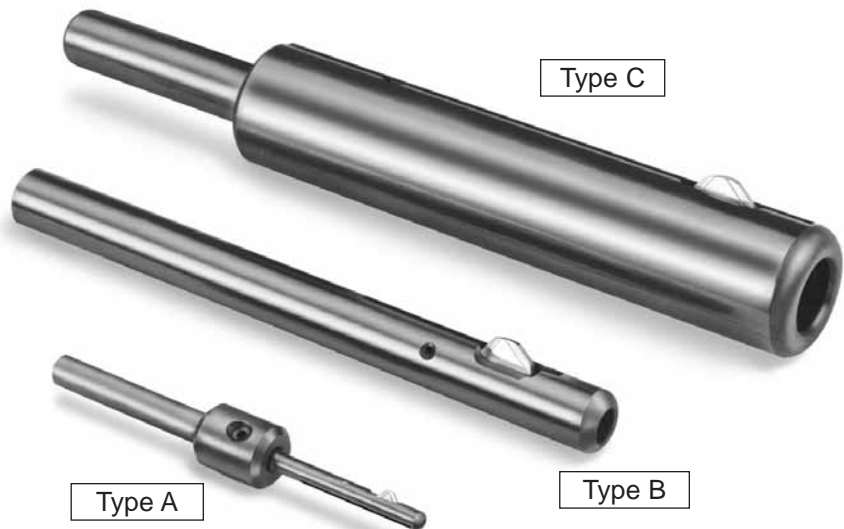

Various blade rake angles and spring tension options are available and recommended for deburring specific material types (see page 10).

Carbide-tipped blades are available upon request for nominal hole sizes of 3/16 inch (4.76mm) and larger. TiN-coated blades are also available upon request.

## A variety of tool designs to meet your needs

Standard BURRAWAY tools are available for *both inch and metric* hole sizes (see pages 6–9).

Standard drill sizes are available from stock. Custom tools – larger sizes, altered standards, or special designs – can also be supplied to suit your particular requirements.

Please furnish a part print and request a quotation. Or, inquire about our free trial and evaluation service: Let us show you how Cogsdill's BURRAWAY tool can help you produce *better-quality parts, with faster production, and at a lower cost!*



Burraway tools are available from stock for standard drill sizes. The tool can deburr two or more in-line holes in one pass.

# Standard tool specifications

## Inch program

### Type B

(All dimensions below are in inches)

HOLE SIZE	DEC. EQUIV	DIM. A	DIM. B	DIM. C	BLADE SIZE
7/32	.218	4.50	.87	.56	#1
15/64	.234	4.50	.87	.56	#1
1/4	.250	4.50	.87	.56	#1
17/64	.265	4.50	.87	.56	#1
9/32	.281	4.50	.87	.56	#1
19/64	.296	4.50	.96	.68	#2
5/16	.312	4.50	.96	.68	#2
21/64	.328	4.50	.96	.68	#2
11/32	.343	4.50	.96	.68	#2
23/64	.359	5	1.00	.68	#3
3/8	.375	5	1.00	.68	#3
25/64	.390	5	1.00	.68	#3
13/32	.406	5	1.00	.68	#3
27/64	.421	5.50	1.09	.72	#3-1/2
7/16	.437	5.50	1.09	.72	#3-1/2
29/64	.453	5.50	1.09	.72	#3-1/2
15/32	.468	5.50	1.09	.72	#3-1/2
31/64	.484	5.50	1.09	.72	#3-1/2
1/2	.500	5.50	1.09	.72	#3-1/2
33/64	.515	5.50	1.09	.72	#3-1/2
17/32	.531	5.50	1.09	.72	#3-1/2
35/64	.546	6.44	1.31	.90	#4
9/16	.562	6.44	1.31	.90	#4
37/64	.578	6.44	1.31	.90	#4
19/32	.593	6.44	1.31	.90	#4
39/64	.609	6.44	1.31	.90	#4
5/8	.625	6.44	1.31	.90	#4
41/64	.640	6.44	1.31	.90	#4
21/32	.656	6.44	1.31	.90	#4
43/64	.671	6.44	1.31	.90	#4
11/16	.687	6.44	1.31	.90	#4
3/4	.750	6.44	1.31	.90	#4

Intermediate sizes are available; request quotation.

### Type A

(All dimensions below are in inches)

HOLE SIZE	DEC. EQUIV	DIM. A	DIM. B	DIM. C	BLADE SIZE
3/32	.093	3.37	.45	.28	3/32*
7/64	.109	3.37	.45	.28	3/32*
1/8	.125	3.37	.45	.25	1/8
9/64	.140	3.37	.45	.25	1/8
5/32	.156	3.37	.45	.25	5/32
11/64	.171	3.37	.45	.25	5/32
3/16	.187	4.12	.72	.44	3/16
13/64	.203	4.12	.72	.44	3/16

\*See "Burraway Blade Data," page 10, refer to note under "Blade Replacement."

Intermediate sizes are available; request quotation.

### Type C

(All dimensions below are in inches)

HOLE SIZE	DEC. EQUIV	BLADE SIZE
3/4	.750	#110
13/16	.812	#110
7/8	.875	#110
15/16	.937	#110
1	1.000	#110
1-1/16	1.062	#110
1-1/8	1.125	#110
1-3/16	1.187	#110
1-1/4	1.250	#110
1-5/16	1.312	#110
1-3/8	1.375	#110
1-1/2	1.500	#110
1-5/8	1.625	#110
1-3/4	1.750	#110
2	2.000	#110

Intermediate sizes, and tools for diameters larger than shown, are available; request quotation.

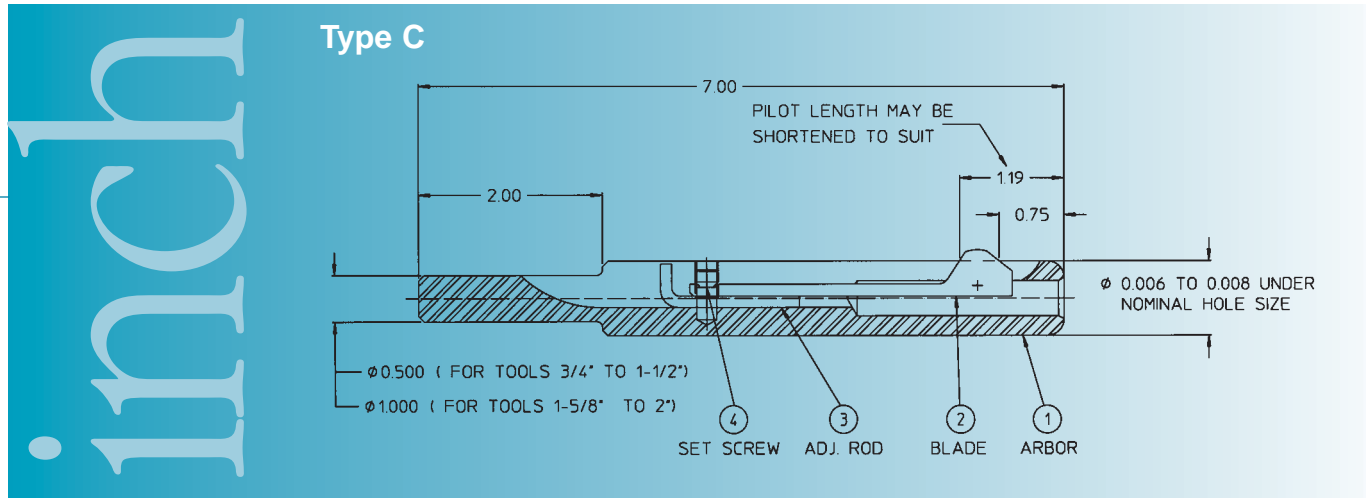
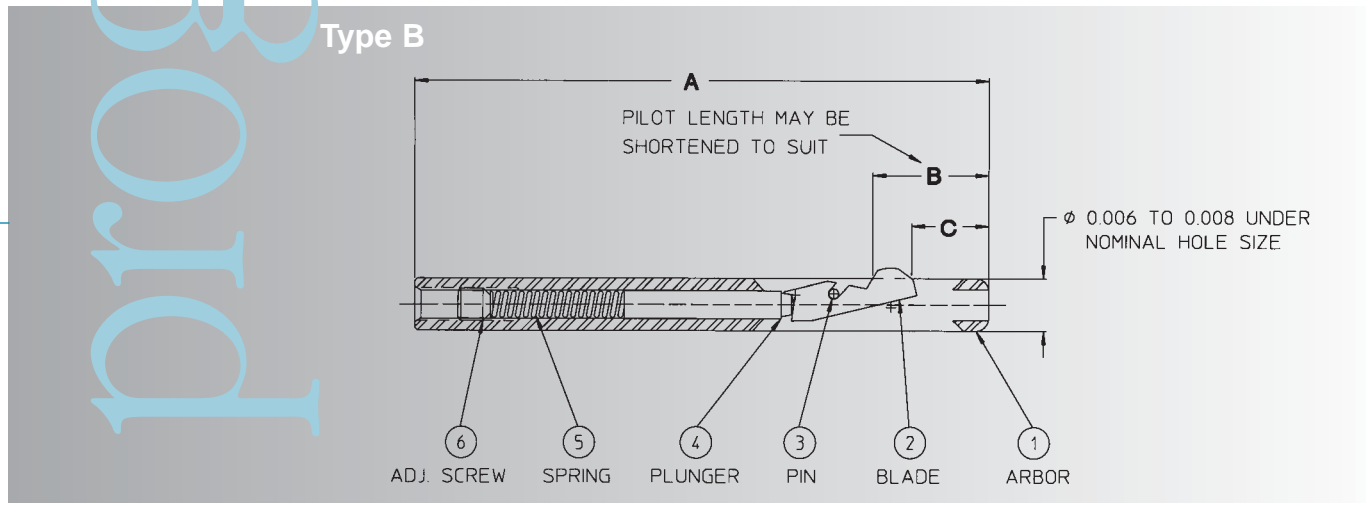
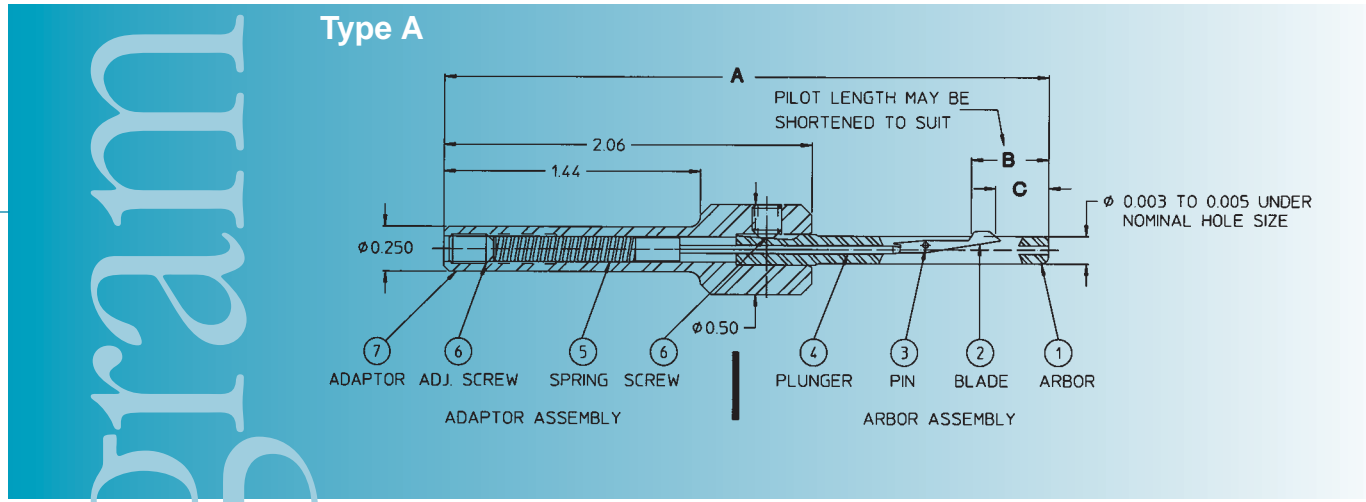

inch program

# Standard tool specifications

Metric program

## Type MB

(All dimensions below are in millimeters)

HOLE SIZE	DIM. A	DIM. B	DIM. C	BLADE SIZE
5.5	114	22.1	14.2	#1
6.0	114	22.1	14.2	#1
6.5	114	22.1	14.2	#1
7.0	114	22.1	14.2	#1
7.5	114	24.4	17.3	#2
8.0	114	24.4	17.3	#2
8.5	114	24.4	17.3	#2
9.0	127	25.4	17.3	#3
9.5	127	25.4	17.3	#3
10.0	127	25.4	17.3	#3
10.5	140	26.2	18.3	#3-1/2
11.0	140	26.2	18.3	#3-1/2
11.5	140	26.2	18.3	#3-1/2
12.0	140	26.2	18.3	#3-1/2
12.5	140	26.2	18.3	#3-1/2
13.0	140	26.2	18.3	#3-1/2
13.5	140	26.2	18.3	#3-1/2
14.0	165	33.3	22.9	#4
14.5	165	33.3	22.9	#4
15.0	165	33.3	22.9	#4
15.5	165	33.3	22.9	#4
16.0	165	33.3	22.9	#4
16.5	165	33.3	22.9	#4
17.0	165	33.3	22.9	#4
17.5	165	33.3	22.9	#4
18.0	165	33.3	22.9	#4
18.5	165	33.3	22.9	#4
19.0	165	33.3	22.9	#4

Intermediate sizes are available; request quotation.

## Type MA

(All dimensions below are in millimeters)

HOLE SIZE	DIM. A	DIM. B	DIM. C	BLADE SIZE
2.0	84.6	11.4	6.4	2.0mm*
2.5	84.6	11.4	6.4	3/32*
3.0	84.6	11.4	6.4	3.0mm
3.5	84.6	11.4	6.4	1/8
4.0	84.6	11.4	6.4	5/32
4.5	103.4	18.3	11.2	3/16
5.0	103.4	18.3	11.2	3/16

\*See "Burraway Blade Data," page 10, refer to note under "Blade Replacement."

Intermediate sizes are available; request quotation.

## Type MC

(All dimensions below are in millimeters)

HOLE SIZE	BLADE SIZE
20.0	#110
25.0	#110
30.0	#110
35.0	#110
40.0	#110
45.0	#110
50.0	#110

Intermediate sizes and tools for diameters larger than shown are available; request quotation.

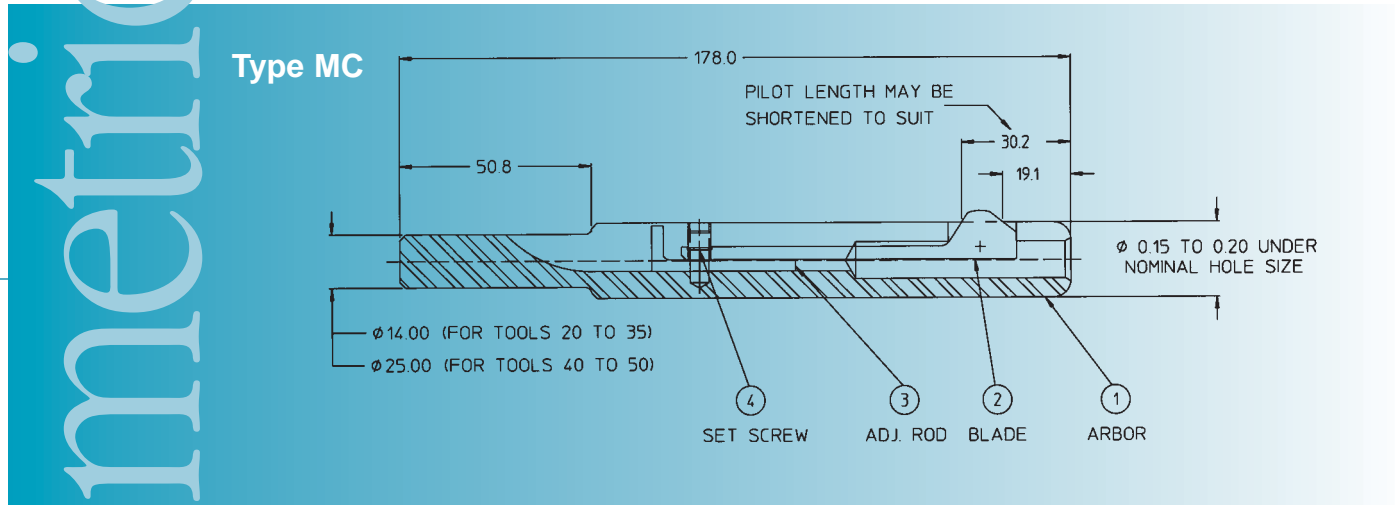
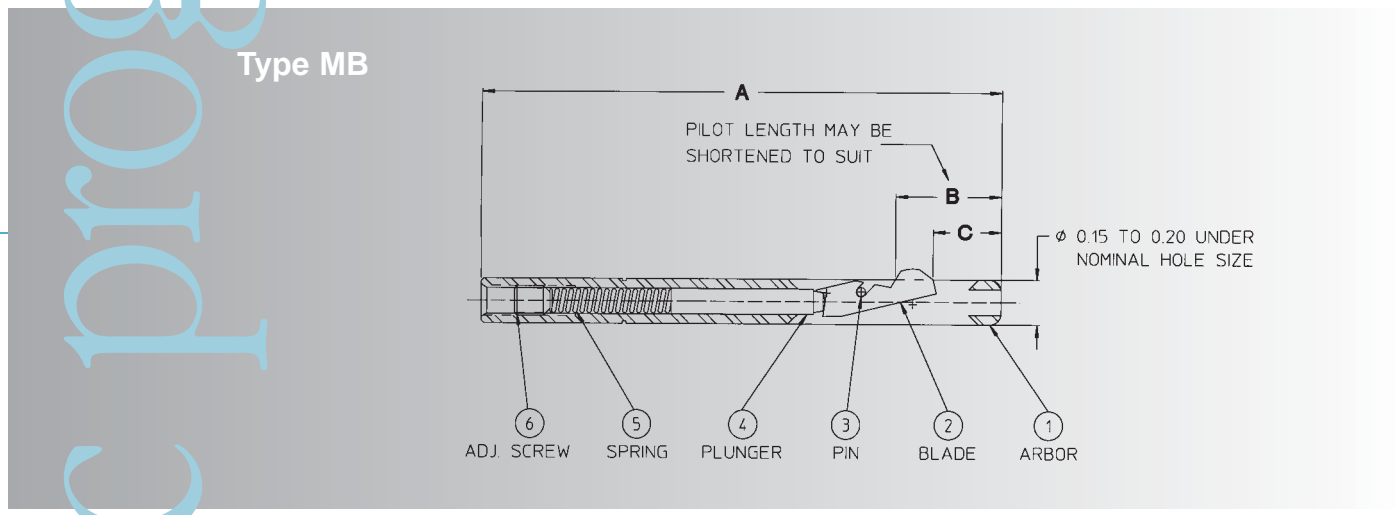
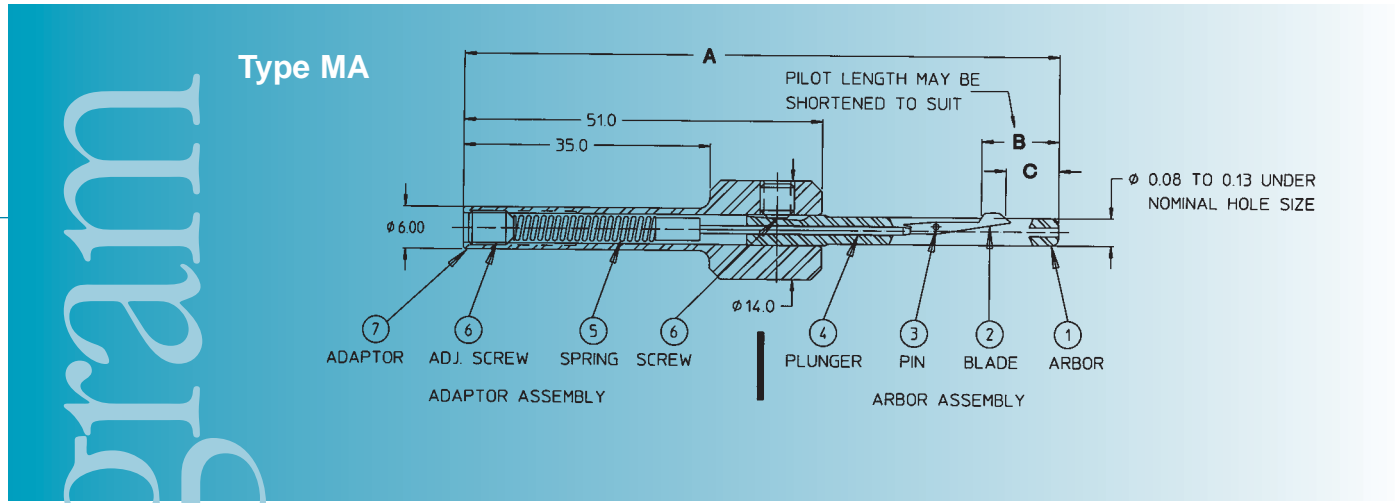

metric program

# Blade data

## Three blade styles

### Double-Acting (DA)

For deburring *both front and back* of holes.

### Back-Acting (BA)

For deburring *back of hole only*.

### Front-Acting (FA)

For deburring *front of hole only*.

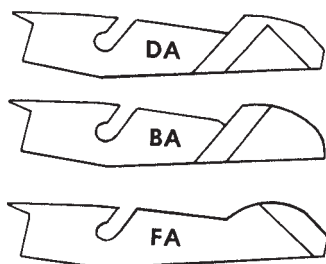

**Note:** Unless otherwise specified, the double-acting blade is furnished with the BURRAWAY tool.

## Blade rake angles

The three styles shown above are available from stock as standard items, with positive rake angles. Negative and neutral rake blades are available from stock upon request as a standard option for certain material types (see chart on the right); otherwise, the positive rake blade will be supplied.

## Blade replacement

Blade replacement is easy for tools in nominal sizes from 3.0mm (.118 in.) and larger. When the tension adjustment screw, located in the end of the shank on Type A and B tools, is loosened sufficiently, the open-ended slot allows the blade to slide out freely. The replacement blade is then installed and the tension adjustment screw retightened for the desired amount of spring tension.



Type A and B blade

For Type C tools, loosen the tension adjustment set screw located on the O.D. of the arbor and slide out both the Type C blade and the tension adjustment rod. Replace in reverse order.

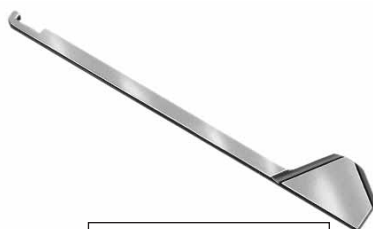

Type C blade

**Note:** BURRAWAY blades for nominal tool sizes of 3/32 and 7/64 inch (.093 and .109) in our inch program, and blades for 2.0 and 2.5mm tools in our metric program, are designed with a pinhole instead of a slot. The open-ended slot is not feasible in this size range due to the small size of the blade. The blade can only be replaced by removing the pivot pin from the arbor, which may cause breakage. We do **not** recommend blade replacement in these smallest tool sizes. We recommend that the entire arbor assembly be replaced.

## Blade recommendations for various material types

Material Type	Blade Style Recommendation
Machine steel Tool steel Steel forgings Malleable iron Monel metal Stainless steel Titanium	4° positive rake blade
Cast iron	0° neutral rake blade
Aluminum	0° neutral rake blade
Brass & bronze	4° negative rake blade

**Note:** Unless you specify otherwise, your tool will be supplied with a double-acting, positive rake blade and a regular-duty spring. Light-duty springs are available upon request for softer non-ferrous materials.

# Tool adjustment & operating recommendations

## Versatile and easy to use

The BURRAWAY® can be used on portable power tools and drill motors, drill presses, automatic equipment, CNC machines, or on virtually any type of shop equipment. No special operator skills are required.

## Fast and easy adjustment

The amount of stock removed will vary with the hardness of the material. Adjust the set screw in the shank end of the tool to obtain the desired edge break. (Caution: Be careful not to over-adjust; if the spring is compressed to a solid condition, the blade will not be able to retract.)

If adjustment fails to produce the desired results, a different blade rake angle or a light-duty spring may be required. Please submit part prints for development of the most efficient tooling for the application.

## Speeds and feeds

Use the same speed and feed rate as you would run a standard HSS drill. The operator will soon acquire a feel for the operation and for the moderate rate of hand feeding which is required to deburr the part.

## Blade life and regrinding

BURRAWAY blades generally last about four to ten times longer than the drill used to make the hole. Due to the low cost of replacement blades, most of our customers prefer to replace worn

blades with new ones.

However, the blades can be reground and reused. Blades can generally take from five to ten regrinds of .010 inch (0.25mm) each before they must be discarded. Regrind clearance angles as shown in Figure 1 below.

## Tool maintenance

The BURRAWAY tool should be inspected periodically for chips, grit, and foreign particles in the slot from which the blade projects. Clean as necessary.

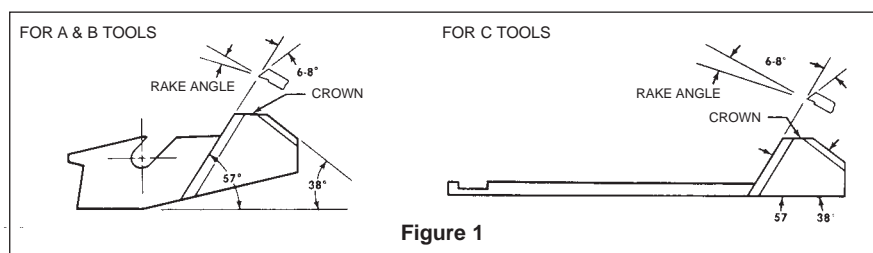

Figure 1

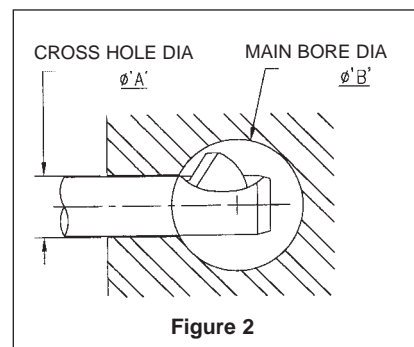

Figure 2

## Cross-hole deburring

Burraway tools will tend to cut an elliptical chamfer when deburring a hole drilled through the wall of a larger hole (i.e., the amount of edge break will be inconsistent). If the ratio of the main bore diameter "B" to the cross-hole diameter "A" is less than 3/1 (refer to Figure 2), the Burraway is not recommended. If the ratio is 3/1 or greater, the standard Burraway tool should be tested and may provide satisfactory results. If not, consider using a tool with a special Burraway blade with a 45° angle, run at speeds of 40-100 RPM; contact our engineering department.

If the ratio is questionable, our Burr-Off tool may be considered (see page 12). While it will tend to cut a greater ellipse, it will also resist breakage on steep side walls. Neither the Burraway nor the Burr-Off is recommended for holes that do not intersect squarely or diametrically.

## Burraway Kit



Our BURRAWAY® Kit contains five deburring tools in popular hole sizes:

- 1/8 in.
- 5/32 in.
- 3/16 in.
- 7/32 in.
- 1/4 in.

A replacement blade for each tool is included. The kit is packaged in a durable box. The BURRAWAY Kit enables you to have on hand the solution to burr removal problems for hole sizes most frequently encountered.

## How it works

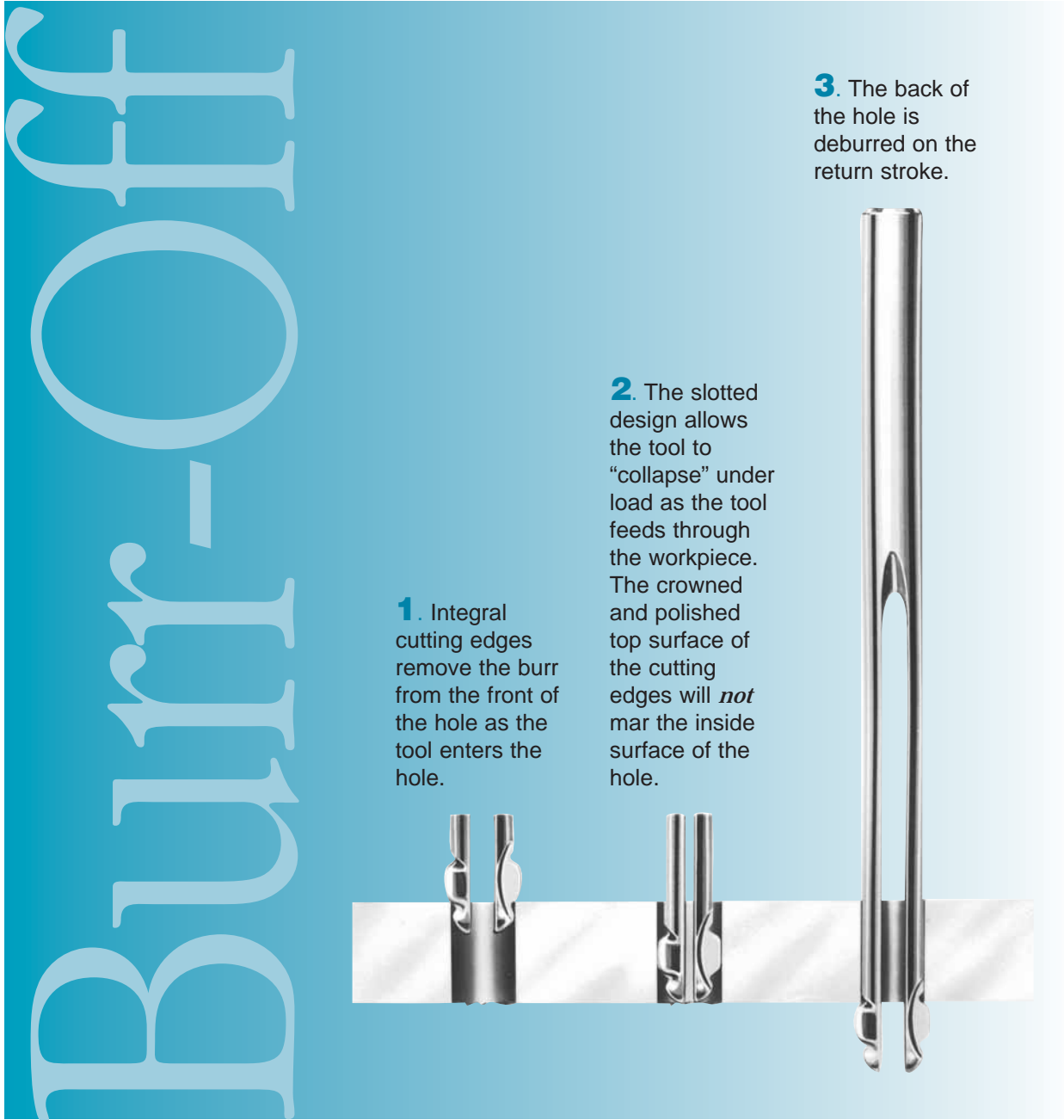

*The BURR-OFF® operates on the same basic principle as the BURRAWAY®, but is designed for high-production, automated deburring operations. The open-slot design of the “clothespin tool” allows chips to clear easily, which makes the tool ideal for automatic equipment and multi-spindle machines.*

*Just like the BURRAWAY, the BURR-OFF deburrs the front, back, or both sides of holes in one fast pass.*

## Design features

The BURR-OFF® is a simple one-piece construction. The integral cutting edges can be altered upon request for front or back-cutting only.

All BURR-OFFS except CP-6 through CP-9 come equipped with a sliding tension-adjustment feature to control the amount of edge break.

### Standard and special tool designs to suit your requirements

In addition to our standard BURR-OFF tools, custom tools are available upon request. Larger sizes, altered standards, and special designs can be supplied to suit your requirements.

Furnish a part print for a quotation, or inquire about our free trial and evaluation service.



CP-6 through -13, for hole sizes from .093 inch (.236mm) through .219 inch (5.56mm), have a single cutting edge. Larger tools feature two cutting edges.

# Standard tool specifications

Burr-Off®

TOOL NUMBER	RANGE OF HOLE SIZES		SHANK DIAMETER		OVERALL LENGTH		DIM. A		DIM. B	
	in.	mm	in.	mm	in.	mm	in.	mm	in.	mm
CP-6	.093-.109	2.36-2.77	.092	2.34	4.00	101.6	.09	2.36	.25	6.35
CP-7	.109-.125	2.77-3.17	.108	2.74	4.00	101.6	.09	2.36	.25	6.35
CP-8	.125-.140	3.17-3.55	.124	3.14	4.00	101.6	.13	3.30	.30	7.62
CP-9	.140-.156	3.55-3.96	.139	3.53	4.00	101.6	.13	3.30	.30	7.62
CP-10	.156-.172	3.96-4.36	.155	3.93	4.00	101.6	.13	3.30	.30	7.62
CP-11	.172-.187	4.36-4.74	.171	4.34	4.00	101.6	.13	3.30	.30	7.62
CP-12	.187-.203	4.74-5.15	.186	4.72	4.00	101.6	.13	3.30	.37	9.39
CP-13	.203-.219	5.15-5.56	.202	5.13	4.00	101.6	.13	3.30	.37	9.39
CP-14	.219-.234	5.56-5.94	.218	5.53	4.00	101.6	.25	6.35	.50	12.7
CP-15	.234-.250	5.94-6.35	.233	5.91	4.00	101.6	.25	6.35	.50	12.7
CP-16	.250-.266	6.35-6.75	.249	6.32	4.00	101.6	.25	6.35	.50	12.7
CP-17	.266-.281	6.75-7.13	.265	6.73	4.00	101.6	.25	6.35	.50	12.7
CP-18	.281-.297	7.13-7.54	.280	7.11	4.00	101.6	.25	6.35	.50	12.7
CP-19	.297-.313	7.54-7.95	.296	7.51	4.00	101.6	.29	7.36	.54	13.71
CP-20	.313-.328	7.95-8.33	.312	7.92	4.00	101.6	.29	7.36	.54	13.71
CP-21	.328-.343	8.33-8.71	.327	8.3	4.00	101.6	.29	7.36	.54	13.71
CP-22	.343-.359	8.71-9.11	.342	8.68	4.00	101.6	.29	7.36	.54	13.71
CP-23	.359-.375	9.11-9.52	.358	9.09	4.00	101.6	.29	7.36	.54	13.71
CP-24	.375-.390	9.52-9.9	.374	9.49	4.43	112.5	.32	8.12	.55	13.97
CP-25	.390-.406	9.9-10.31	.389	9.88	4.43	112.5	.32	8.12	.55	13.97
CP-26	.406-.422	10.31-10.71	.405	10.28	4.43	112.5	.32	8.12	.55	13.97
CP-27	.422-.437	10.71-11.09	.420	10.66	4.43	112.5	.32	8.12	.55	13.97
CP-28	.437-.453	11.09-11.5	.436	11.07	5.50	139.7	.35	8.89	.62	15.74
CP-29	.453-.468	11.5-11.88	.452	11.48	5.50	139.7	.35	8.89	.62	15.74
CP-30	.468-.484	11.88-12.29	.467	11.86	5.50	139.7	.35	8.89	.62	15.74
CP-31	.484-.500	12.29-12.7	.483	12.26	5.50	139.7	.35	8.89	.62	15.74
CP-32	.500-.515	12.7-13.08	.499	12.67	7.00	177.8	.38	9.65	.68	17.27
CP-33	.515-.531	13.08-13.48	.514	13.05	7.00	177.8	.38	9.65	.68	17.27
CP-34	.531-.547	13.48-13.89	.530	13.46	7.00	177.8	.38	9.65	.68	17.27
CP-35	.547-.563	13.89-14.3	.545	13.84	7.00	177.8	.38	9.65	.68	17.27
CP-36	.563-.578	14.3-14.68	.562	14.27	7.50	190.5	.42	10.66	.82	20.82
CP-37	.578-.594	14.68-15.08	.577	14.65	7.50	190.5	.42	10.66	.82	20.82
CP-38	.594-.609	15.08-15.46	.593	15.06	7.50	190.5	.42	10.66	.81	20.57
CP-39	.609-.625	15.46-15.87	.608	15.44	7.50	190.5	.42	10.66	.81	20.57
CP-40	.625-.641	15.87-16.28	.624	15.84	7.50	190.5	.45	11.43	.88	22.35

Tools for larger hole sizes up to 1.000 inch (25.4mm) are available; request quotation.

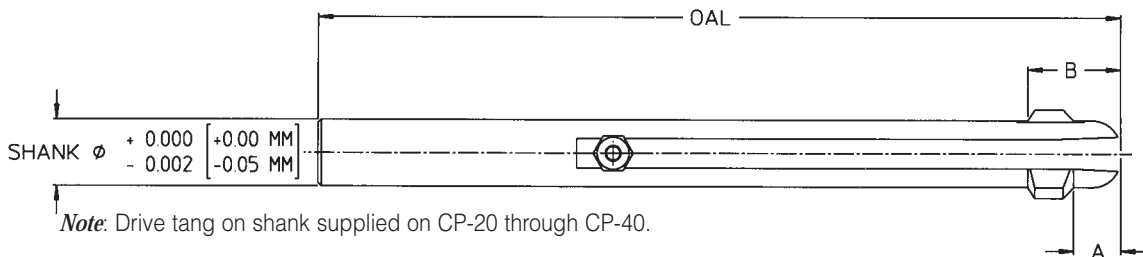

# Tool adjustment & operating recommendations

## Fast and easy adjustment

The amount of edge break will vary with the hardness of the material. Loosen the screw on the sliding tension-adjustment mechanism and move it up or down the length of the slot for more or less stock removal.

## Speeds and feeds

As with BURRAWAY tools, use the same speed and feed rate as you would run a standard HSS drill.

## Tool maintenance and edge resharpening

The BURR-OFF should be inspected periodically for grit and foreign particles, and cleaned as necessary.

The cutting edges may be reground up to four times in order to extend tool life. Refer to Figure 2 below for the proper regrind procedure.

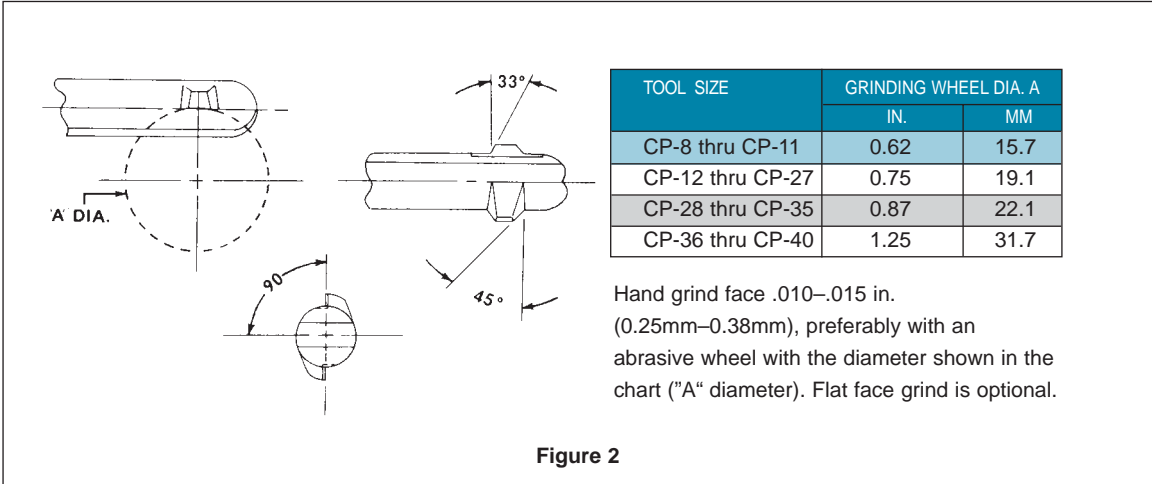

Figure 2

# How it works

# Micro-Limit

*The MICRO-LIMIT is a precision depth-control countersinking tool. The tool consists of a drive with a piloted countersink and a depth-control adjustment feature.*

The tool is pre-set to the desired depth of cut. The selected setting is locked in for accurate and consistent results from part to part.

The pilot is engaged in the hole. A stop collar seats on the face of the workpiece; the tool advances to countersink the hole to the desired depth.

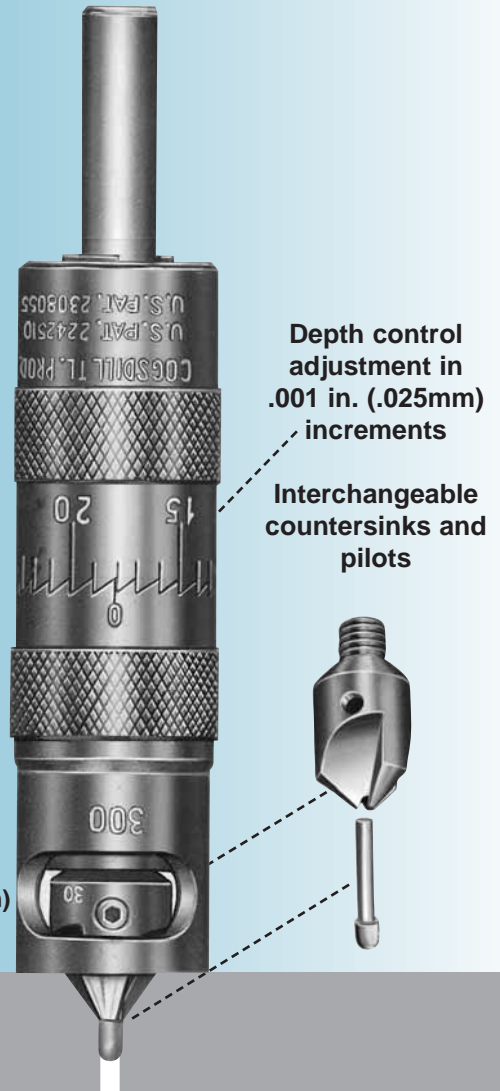
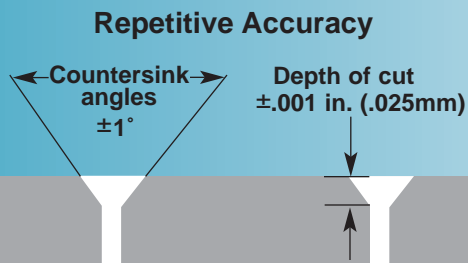

## Design features

The Micro-Limit drive is designed and built for rugged production work. The thrust load is taken up on ball bearings through a hardened steel stop collar. The drive shaft rides on needle bearings. This design makes our drive the longest lasting in the industry.

Adjustment is in increments of .001 inch (.025mm).

Three drive models cover a wide range of hole sizes.

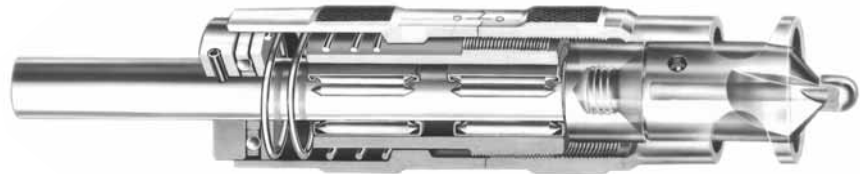

## Countersinks & pilots

An array of interchangeable countersinks and pilots are available as standard (refer to tool specifications on page 18 ).

Countersinks are offered with three standard angles. Special angles and carbide-tipped countersinks are available upon request.

Pilots for hole sizes from .125 to .500 inch (3.17 to 12.7mm) are standard; intermediate sizes are available upon request.

## Optional overtravel feature

The MICRO-LIMIT is also offered with an overtravel unit built into the standard drive.\* Ideally suited to automatic applications, the overtravel feature compensates for variations in part thickness and for overtravel of the machine spindle up to .125 inch (3.17mm).

The MICRO-LIMIT with overtravel also simplifies set-up for applications on multiple spindles.

\*Available only on #300 and #400 drives.

## Custom designs available to suit your requirements

Altered standards and special designs are available upon request. Furnish a part print for a quotation.



MICRO-LIMIT drive with overtravel

# Standard tool specifications

## Drives

TOOL NUMBER	"A"		"B"		"C"		"D"		"E"		"F"	
	in.	mm	in.	mm	in.	mm	in.	mm	in.	mm	in.	mm
200	.187	4.75	.92	23.36	3.87	98.29	.62	15.74	.47	11.93	.62	15.74
300	.312	7.92	1.04	26.41	4.25	107.95	.84	21.33	.62	15.74	.75	19.05
300 OT*	.500	12.7	1.50	38.1	6.50	165.1	.84	21.33	.62	15.74	.75	19.05
400	.312	7.92	1.04	26.41	4.81	122.17	.84	21.33	1.03	26.16	1.18	29.97
400 OT*	.500	12.7	1.50	38.1	7.25	184.15	.84	21.33	1.03	26.16	1.18	29.97

\*With overtravel.

## Countersinks

TOOL NUMBER	SERIES	STANDARD ANGLES*	"A"		"B"		"C"	
			in	mm	in	mm		
200	20	82°	5/16-32	.390	9.9	.125	3.17	
300 & 300 OT	30	90°	1/4-28	.500	12.7	.125	3.17	
400 & 400 OT	40	100°	7/16-20	.875	22.22	.218	5.53	

\*Standard angles shown are available for each series; other angles are available upon request. Carbide-tipped countersinks are also available upon request.

## Pilots

TOOL NUMBER	SERIES	STANDARD PILOT HOLE SIZES (IN.)	"A"	
			in	mm
200 300 300 OT	3	.125	.093	2.36
		.128		
		.156		
		.161		
		.187		
		.250		
400 400 OT	4	.312	.187	4.74
		.250		
		.375		
		.500		

Available in intermediate diameters.

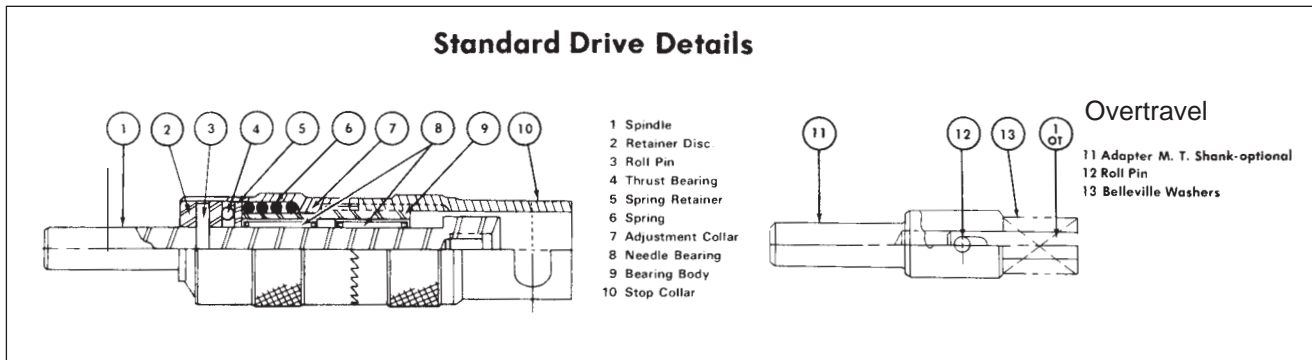

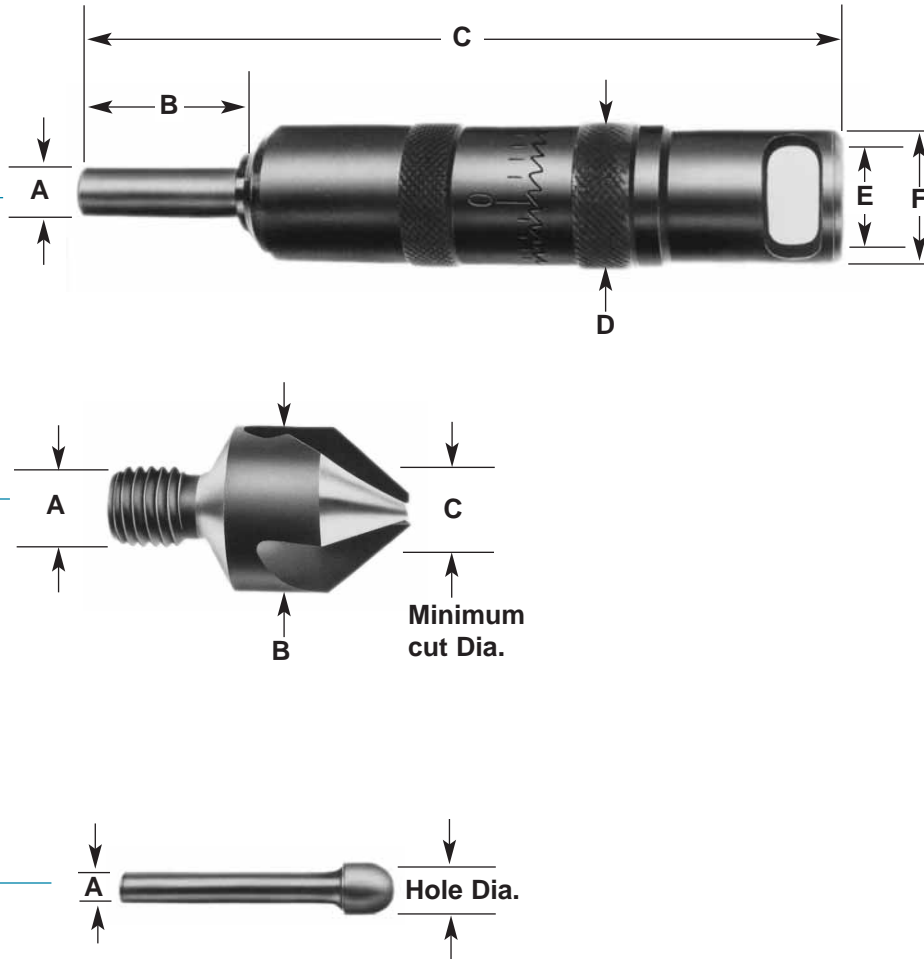

## Tool adjustment & operating recommendations

### Versatile, easy to use

Use the MICRO-LIMIT on virtually any type of shop equipment. No special operator skills are required.

### Quick and easy adjustment

Adjustments are made by hand-indexing the castellated adjustment collar to control the depth of cut. Adjustment is in increments of .001 inch (.025mm).

### Speeds and feeds

Use approximately the same speed and feed rate as with a standard HSS drill. However, the greater the depth of cut, the slower the speed required to avoid chatter.

### Tool maintenance

For long tool life, the MICRO-LIMIT should be kept free of grit, chips,

and foreign matter.

The countersink should be replaced when the cutting edges become dull. Loosen the set screw in the side of the countersink to remove the pilot. Unscrew the countersink to remove it from the drive spindle, and replace with a new one.

## How it works

# Ellipti-Bur

*The ELLIPTI-BUR® is designed for deburring irregular hole surfaces, such as those which are generated by drilling into curved surfaces, or by drilling at an angle. The ELLIPTI-BUR enables the user to perform these difficult deburring operations quickly and accurately, and without jigs, fixtures, or special operator skills.*

As the pilot of the tool is located in the hole, the tool is seated and centered. As the tool is advanced, the pilot is forced into the tool body against the shank spring, and the blade comes into contact with the edge of the hole. As the tool continues to advance, the pilot is further pressed into the body and the blade is driven into the workpiece.

The blade remains free to react to the irregular surface geometry of the hole, allowing for both radial and axial displacement- radial displacement resulting from the elliptical shape of angularly-drilled holes, and axial displacement ("rise and fall") from the saddle-shaped configuration of holes drilled in cylindrical surfaces.

This automatic self-guiding feature produces a relatively uniform break on the edge of the hole.

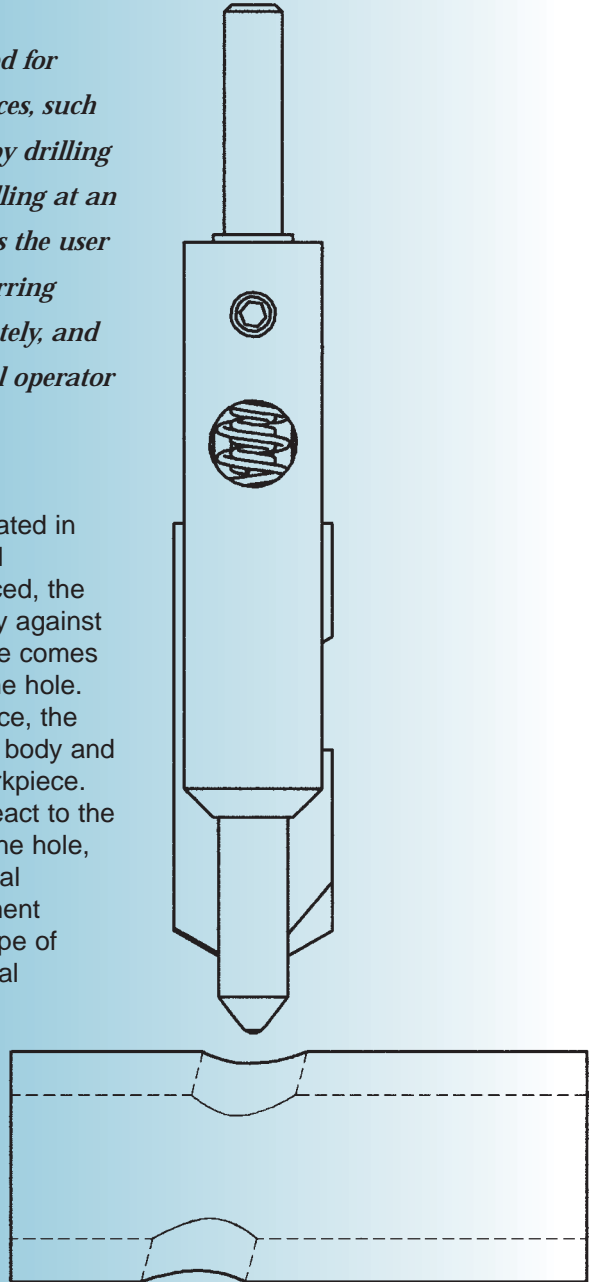

## Design features

The ELLIPTI-BUR features a spring-loaded and self-centering conical pilot to locate and seat the tool for consistent results. All essential tool parts are hardened and ground for durability.

Three models cover a range of hole sizes from 5/32 to one inch (3.96 to 25.4mm).

The blade, which has two diametrically opposed cutting edges, is made from hardened high-speed steel and finish ground. A supplemental surface treatment provides for increased wear resistance.



# Standard tool specifications

## Ellipti-Bur®

TOOL NO.	OPERATING RANGE				"C"		"D"		"E"		"F" DEGREE
	"A" (min.)		"B" (max.)		LENGTH		BODY		SHANK		
	in.	mm	in.	mm	in.	mm	in.	mm	in.	mm	
EL-5	.156	3.96	.312	7.93	3.125	79.37	.625	15.87	.250	6.35	120°
*EL-5XT	.156	3.96	.312	7.93	3.125	79.37	.625	15.87	.250	6.35	120°
EL-8	.250	6.35	.500	12.7	3.250	82.55	.750	19.05	.250	6.35	120°
EL-16	.375	9.52	1.000	25.4	4.750	120.65	1.000	25.4	.500	12.7	120°

\*Blades for the EL-5XT are made from a premium grade high speed steel and recommended for applications where longer tool life is desired, such as when coolant is unavailable.

Note: Operating range is determined by pilot diameter, not by cutter width.

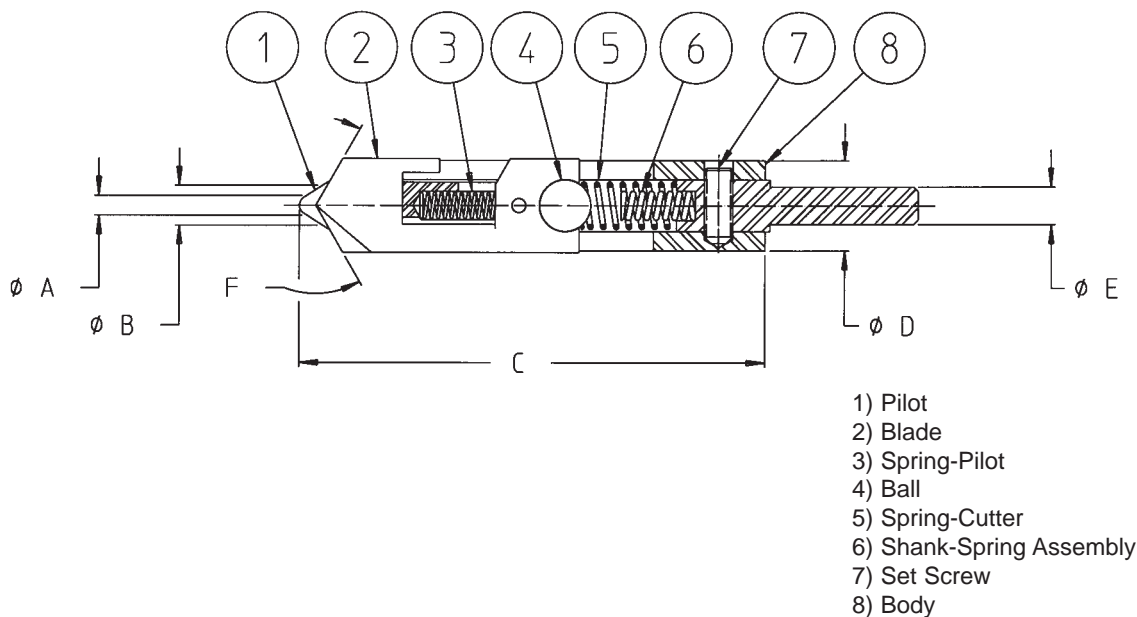

# Tool adjustment & operating recommendations

## Versatile, fast, safe, and easy

ELLIPTI-BUR® tools can be used on portable power tools and drill motors, drill presses, automatic equipment, CNC machines, or on virtually any type of shop equipment.

The tool is fast, safe, and easy to handle. The pilot engages the hole. The blade, *not* the tool body, reacts to accommodate the irregular hole geometry.

## Speeds and feeds

The most desirable speed for a particular application can best be determined by trial. Spindle speeds must be relatively slow to enable the blade to accommodate a continuously changing path in the course of each revolution.

The speed recommendations below will serve as a guideline:

- Speeds up to 600 RPM are generally recommended where the following conditions exist:
  - (1) Where holes are drilled into a flat surface at an angle not exceeding 15°.
  - (2) Where holes are drilled into a cylindrical part with a diameter which is 6 or more times *greater* than the hole size.
- Speeds of 100-300 RPM may be required where more difficult conditions exist, such as:
  - (1) Holes drilled at a severe angle.
  - (2) Holes drilled into a cylindrical part where the diameter is *less* than 6 times the hole size.

Feeds are not a critical issue with the ELLIPTI-BUR. Only a light

contact pressure is required to deburr and produce a small edge break. The amount of stock removal is determined by the pressure applied and the dwell time.

## Application considerations

A proper drilling technique is necessary in order to maximize the effectiveness of the ELLIPTI-BUR. The following guidelines will help you *avoid creating an excessive burr*:

- Drill points should have a 130-150° included angle, rather than the conventional 118°.
- Slow-spiral drills generally allow better breakthrough than fast-spiral drills.
- A uniformly controlled feed rate (preferably power feed) is required in order to prevent an accelerated advance of the drill at the point of breakthrough.
- The workpiece should be held securely.

## Application restrictions

The ELLIPTI-BUR is generally *not* recommended for:

- Extremely soft, ductile metals.
- Applications where the diameter of a cylindrical part having a cross-drilled hole is *less* than 2-1/2 times the diameter of the drilled hole. (Note: The softer and more ductile the material, the more this limitation applies.)

## Blade replacement and regrinding

The ELLIPTI-BUR blade can be easily replaced by following this procedure (refer to the details drawing on page 22):

- 1.Remove Detail 7 Retaining Screw. (*Note:* Tool is spring-loaded.)
- 2.Remove Det. 6 Shank Spring Assembly.
- 3.Remove Det. 3 Blade Spring.
- 4.Remove Det. 4 Chrome Steel Retaining Ball.
- 5.Slide Det. 1 Pilot and Det. 2 Blade from Det. 8 Tool Body.
- 6.Remove Pilot from Blade. (*Note:* spring-loaded.)
- 7.Replace Blade.
- 8.Reassemble in reverse order. (*Important:* Blade must be inserted in tool body so that it can float freely.)

Replacement blades are inexpensive; however, the blades can be reground in the user's shop. Please refer to Figure 3 for proper regrind procedure.

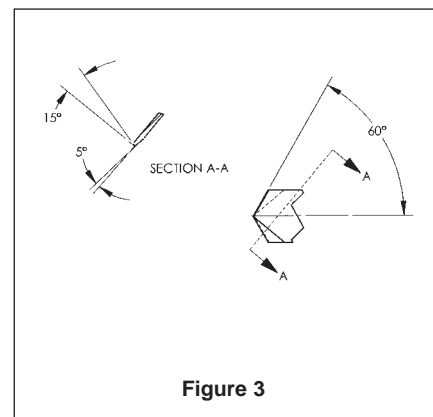

Figure 3

# How it works

*The NOBUR<sup>®</sup> Tool is a manually actuated deburring and chamfering tool for use where production requirements are low. The tool is used on multi-walled parts and on intersecting holes. It will remove severe burrs and will produce non-qualified chamfers. The tool body pilots in the hole to be deburred. A quick-action*

*sliding sleeve extends the retractable, double-edged cutting blade to deburr or chamfer the front, back, or both sides of holes, in one pass of the tool.*

*Since the tool is manually actuated while the spindle continues to run, there is no "on-off" down time.*

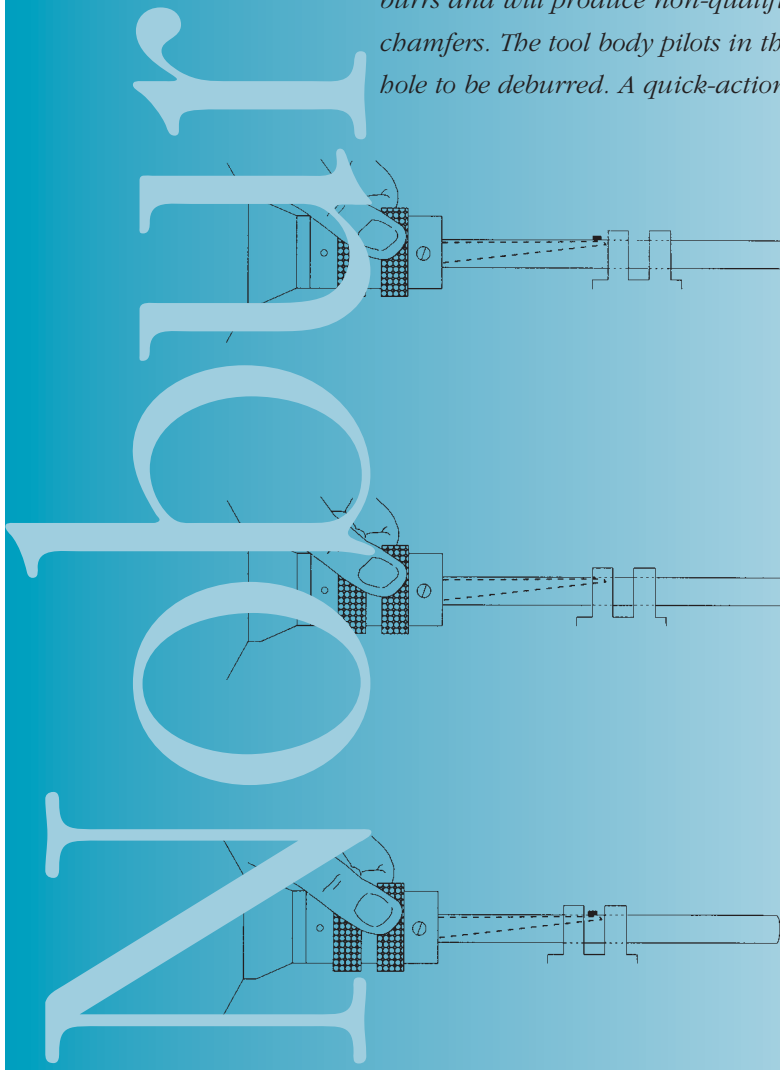

**1.** The tool should be running in a spindle with the cutting blade in the extended position. The tool is fed into the workpiece. The burr on the outer edge of the first wall is quickly and easily removed.

**2.** The sliding sleeve is moved backwards to retract the blade. The workpiece is advanced to such a position that, when the blade is again extended by a forward movement of the sleeve, it will lie between the two walls. The burr on the inner edge of the first wall is then easily removed.

**3.** Continued advancement of the tool allows the inner edge of the second wall to be deburred. The sleeve is moved backwards once again to retract the blade so that it can pass through the hole in the second wall. The blade is again extended to deburr the outer edge of the second wall.

*The above steps can be repeated as many times as necessary, depending upon the number of walls in the part. Work is performed continuously, without having to stop the spindle.*

## Design features

The NOBUR Tool has a free-rolling knurled sleeve, mounted on ball bearings, which allows for fast and easy manual retraction and extension of the blade. The pilot is chrome-plated for long tool life.

Standard sizes range from 3/32 to one inch (2.38 to 25.4mm). Work lengths range from 9/16 to 4-3/4 inch (14.28 to 120.65mm).



## Blade options for intersecting holes

Three different blade options are available for intersecting hole applications. Blade selection is based upon the ratio of the diameters of the two holes (refer to page 27).

## Special designs available

Custom tools – including altered standards and special sizes and designs – are available upon request. Please furnish a part print and request a quotation.

# Standard tool specifications

## Nobur® Tool

WITH STANDARD CUTTER		WITH MODIFIED CUTTER-1*		WITH MODIFIED CUTTER-2**		Hole Size		"A" Working Depth		"B" Pilot Length		"C" Shank Diameter		"D" Overall	
Tool Number	Chamfer Angle	Tool Number	Chamfer Angle	Tool Number	Chamfer Angle	in.	mm	in.	mm	in.	mm	in.	mm	in.	mm
DS 3/32	45°	DS 3/32-1	45°	DS 3/32-2	45°	.093	2.38	.56	14.28	2.43	61.91	.375	9.52	6.12	155.57
DS 1/8	20°	DS 1/8-1	45°	DS 1/8-2	45°	.125	3.17	1.50	38.1	3.12	79.37	.375	9.52	6.81	173.03
DS 5/32	20°	DS 5/32-1	45°	DS 5/32-2	45°	.156	3.97	1.50	38.1	3.12	79.37	.375	9.52	6.81	173.03
DS 3/16	20°	DS 3/16-1	45°	DS 3/16-2	45°	.187	4.76	1.50	38.1	3.12	79.37	.375	9.52	6.81	173.03
DS #10	20°	DS #10-1	45°	DS #10-2	45°	.193	4.91	1.50	38.1	3.12	79.37	.375	9.52	6.81	173.03
AS 3/16	20°	AS 3/16-1	45°	AS 3/16-2	45°	.187	4.76	1.75	44.45	4.00	101.6	.500	12.7	7.81	198.43
AS #10	20°	AS #10-1	45°	AS #10-2	45°	.193	4.91	1.75	44.45	4.00	101.6	.500	12.7	7.81	198.43
AS 7/32	20°	AS 7/32-1	45°	AS 7/32-2	45°	.218	5.55	1.75	44.45	4.00	101.6	.500	12.7	7.81	198.43
AS 1/4	20°	AS 1/4-1	45°	AS 1/4-2	45°	.250	6.35	1.75	44.45	4.00	101.6	.500	12.7	7.81	198.43
AS 9/32	20°	AS 9/32-1	45°	AS 9/32-2	45°	.281	7.14	1.75	44.45	4.00	101.6	.500	12.7	7.81	198.43
AS 5/16	20°	AS 5/16-1	45°	AS 5/16-2	45°	.312	7.94	1.75	44.45	4.00	101.6	.500	12.7	7.81	198.43
AS 11/32	20°	AS 11/32-1	45°	AS 11/32-2	45°	.343	8.73	1.75	44.45	4.00	101.6	.500	12.7	7.81	198.43
AS 3/8	30°	AS 3/8-1	45°	AS 3/8-2	45°	.375	9.52	2.75	69.85	6.00	152.4	.500	12.7	9.81	249.23
AS 13/32	30°	AS 13/32-1	45°	AS 13/32-2	45°	.406	10.31	2.75	69.85	6.00	152.4	.500	12.7	9.81	249.23
AS 7/16	30°	AS 7/16-1	45°	AS 7/16-2	45°	.437	11.11	2.75	69.85	6.00	152.4	.500	12.7	9.81	249.23
AS 15/32	30°	AS 15/32-1	45°	AS 15/32-2	45°	.468	11.9	2.75	69.85	6.00	152.4	.500	12.7	9.81	249.23
AS 1/2	30°	AS 1/2-1	45°	AS 1/2-2	45°	.500	12.7	2.75	69.85	6.00	152.4	.500	12.7	9.81	249.23
AS 9/16	30°	AS 9/16-1	45°	AS 9/16-2	45°	.562	14.28	3.75	95.25	8.00	203.2	.500	12.7	11.81	300.03
AS 5/8	30°	AS 5/8-1	45°	AS 5/8-2	45°	.625	15.87	3.75	95.25	8.00	203.2	.500	12.7	11.81	300.03
AS 11/16	30°	AS 11/16-1	45°	AS 11/16-2	45°	.687	17.46	3.75	95.25	8.00	203.2	.500	12.7	11.81	300.03
AS 3/4	30°	AS 3/4-1	45°	AS 3/4-2	45°	.750	19.05	3.75	95.25	8.00	203.2	.500	12.7	11.81	300.03
CS 13/16	30°	CS 13/16-1	45°	CS 13/16-2	45°	.812	20.63	4.75	120.65	10.00	254	.625	15.87	14.37	365.12
CS 7/8	30°	CS 7/8-1	45°	CS 7/8-2	45°	.875	22.22	4.75	120.65	10.00	254	.625	15.87	14.37	365.12
CS 15/16	30°	CS 15/16-1	45°	CS 15/16-2	45°	.937	23.81	4.75	120.65	10.00	254	.625	15.87	14.37	365.12
CS 1	30°	CS 1-1	45°	CS 1-2	45°	1.000	25.4	4.75	120.65	10.00	254	.625	15.87	14.37	365.12

Note: The DS 3/16 and DS #10 duplicate sizes offered in the "AS" series. The "DS" tool offers more rigid blade support than the comparable "AS" tool and is recommended for applications in steel and for heavy burr removal.

\*Used when larger hole is between 6 and 12 diameters larger than smaller hole

\*\*Used when larger hole is between 2-3/4 to 6 diameters greater than smaller hole.

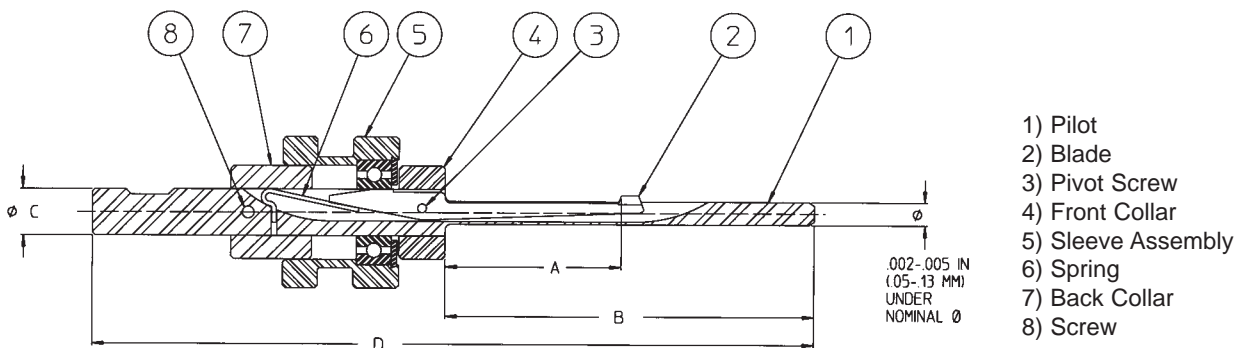

## Blade data

Blades for NOBUR® Tools are manufactured from hardened and precision ground high-speed steel. Three styles are available: standard, and two modified designs (see below for application parameters). For applications other than intersecting holes, the standard blade is used.

### Blades for intersecting hole applications

Intersecting holes can sometimes create problems when using the NOBUR Tool with the standard blade. The following guidelines apply:

*Standard blades* may be used for intersecting hole applications where the larger hole “B” is 12 or more times *greater* than the smaller hole “A” (refer to Figure 4).

*Modified standard blades* are available from stock for intersecting hole applications where the following conditions exist:

- **Modified blade No. 1** is recommended for intersecting holes where the diameter of the larger hole “B” is between 6 to 12 times *greater* than the smaller hole “A.”
- **Modified blade No. 2** is recommended for intersecting holes where the larger hole “B” is 2-3/4 to 6 times *greater* than the smaller hole “A.” (Operating speeds from 25-75 RPM are also recommended for applications within this range of intersecting hole diameter ratios.)

*Note:* The NOBUR Tool is **not** recommended for lower ratios of diameter or for holes which do not intersect squarely.

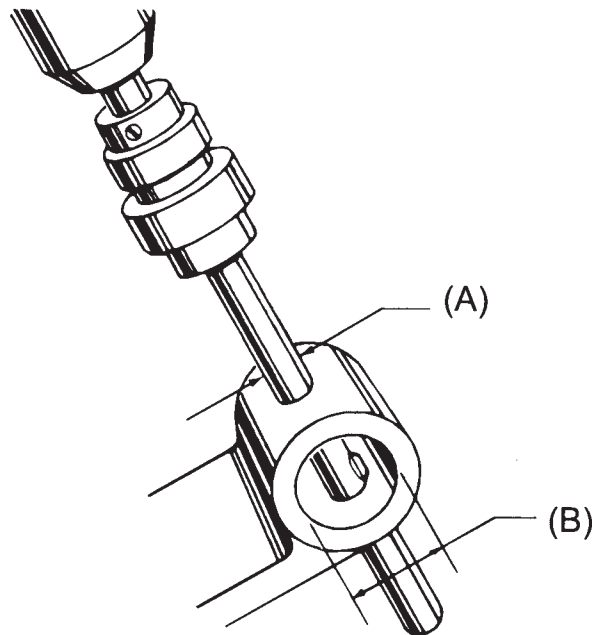

Figure 4

# Tool operating recommendations

## Tool operation

NOBUR® Tools can be run on a drill press, lathe, or any rotating spindle.

## Material types

NOBUR Tools can be applied on steel, stainless steel, brass, bronze, aluminum, or virtually any ferrous or non-ferrous materials.

## Speeds

Low operating speeds are recommended for the NOBUR Tool. A range of 50 to 650 RPM is suggested, with slower speeds required for larger tool sizes and heavy parts.

High spindle speeds will not result in faster production, since only three or four revolutions of the tool are required to remove the burr. High spindle speeds are likely to dull the blade edge, create excessive wear on the pilot shaft, or cause chatter. The part should be supported as necessary.

## Blade replacement and regrinding

The NOBUR Tool blade can be easily replaced by following this procedure (refer to the schematic drawing on page 26):

### For tool numbers #DS 1/8 to #DS 10:

- Remove the back collar.
- Slide the knurled sleeve back to where it just drops free onto the smaller shank diameter.
- Restrict further movement of the blade at this point, and complete the removal of the sleeve.
- Lift the blade out and replace.

### For tool numbers #AS 3/16 to #AS 1/2:

- Slide the knurled sleeve against the back collar so that the blade is retracted within the pilot shaft.
- Remove the pivot screw. This frees the front collar and permits the blade to be lifted out.
- Replace the blade. To re-assemble, the cam edge of the blade must be inserted so as to depress the end of the spring which extends beyond the sleeve.
- Align the front collar and replace the pivot screw. A zero (0) mark is stamped on the front collar of tools #AS 5/16 and smaller to indicate that it is to be positioned in line with the slot on the pilot shaft.

### For tool numbers #AS 9/16 to #AS 3/4:

- Remove the screw from the back collar. Remove the back collar and sleeve. Remove the pivot screw from the front collar and lift the blade out for replacement.
- To re-assemble, replace parts in reverse order. Insert the blade first in such a manner that the spring is depressed.

### For tool numbers, #CS 13/16 to #CS 1:

- Slide the knurled sleeve against the back collar. Remove the pivot screw and lift the blade out and replace.
- To re-assemble, the cam edge of the blade must be inserted in such a manner as to depress the end of the spring which extends beyond the sleeve.

Replacement blades for NOBUR Tools are inexpensive; however, blades may be reground in the user's shop. The blade must be kept

sharp, since a dull blade takes longer to cut and the operator will tend to apply excessive pressure against the work. Refer to Figure 5 for proper regrind procedure.

## Short front pilot

It may be necessary to shorten the front pilot to accommodate blind holes or obstructions. The pilot should be cut off beyond the slot from which the blade projects.

## Tool maintenance

Inspect the tool periodically for chips and foreign particles in the slot of the pilot shaft. Clean as necessary.

A few drops of lubricating oil applied between the sliding sleeve and the back collar will extend the life of the bearing.

